



FORCE

OWNERS MANUAL

ABI FORCE Z-23

REAR PIVOT LIFT SYSTEM



*This instruction document covers several models. Features may vary by model.
Not all features in this document are applicable to all models and the model depicted may differ from yours.*

[VIEW FORCE BY ABI PRODUCT PAGE](#)



FOR YOUR RECORDS:

Record your machine's information and serial number in the space provided below. ABI will use this information to give you prompt service when you order parts or need support.

This document covers several models. Features may vary by model. Not all features in this document are applicable to all models and the model depicted may differ from yours.

MODEL AND SERIAL NUMBER:

Model Number:	_____
Serial Number:	_____
Invoice Number:	_____
Purchaser's Name:	_____

CONTACT INFORMATION:

ABI Attachments, Inc
520 S. Byrkit Ave.
Mishawaka, IN 46544

CUSTOMER SUPPORT:

Email: support@abiattachments.com
Phone: (877)788-7253
Website: abisupport.com

WARRANTY INFORMATION:

Please see separate enclose for warranty details

NOTES:

TABLE OF CONTENTS:

For Your Records & Notes.....	2
Safety.....	3
Warning Labels.....	6
Completed Assembly Photo.....	6
Replacement Parts.....	6
Parts Descriptions.....	7
Assemble Pivoting Hitch.....	9
Setup For First Time Use.....	10
Toplink Attachment.....	11
Force Hydraulic Hitch Revision.....	11
Contact Us.....	12

SAFETY:



WARNING! The SAFETY ALERT SYMBOL indicates there is a potential hazard to personal safety involved and extra safety precaution must be taken. When you see this symbol, be alert and carefully read the message that follows it. In addition to design and configuration of equipment, hazard control, and accident prevention are dependent upon the awareness, concern, prudence, and proper training of personnel involved in the operation, transport, maintenance, and storage of equipment.



CALIFORNIA PROPOSITION 65

WARNING! Cancer and reproductive harm - www.P65Warnings.ca.gov

SAFETY AT ALL TIMES

Careful operation is your best assurance against an accident. All operators, no matter how much experience they may have, should carefully read this manual and other related manuals, or have the manuals read to them, before operating the tow vehicle and this implement.

- Thoroughly read and understand the "Safety Label" section. Read all instructions noted on them.
- Do not operate the equipment while under the influence of drugs or alcohol as they impair the ability to safely and properly operate the equipment.
- The operator should be familiar with all functions of the tow vehicle and attached implement and be able to handle emergencies quickly.
- Make sure all guards and shields appropriate for the operation are in place and secured before operating implement.
- Keep all bystanders away from equipment and work area.
- Start tow vehicle from the driver's seat with hydraulic controls in neutral.
- Operate tow vehicle and controls from the driver's seat only.
- Never dismount from a moving tow vehicle or leave tow vehicle unattended with engine running.
- Do not allow anyone to stand between tow vehicle and implement while backing up to implement.
- Keep hands, feet, and clothing away from power-driven parts.
- While transporting and operating equipment, watch out for objects overhead and along side such as fences, trees, buildings, wires, etc.
- Do not turn tow vehicle so tight as to cause hitched implement to ride up on the tow vehicle's rear wheel.
- Store implement in an area where children normally do not play. When needed, secure attachment against falling with support blocks.

SAFETY PRECAUTIONS FOR CHILDREN

Tragedy can occur if the operator is not alert to the presence of children. Children generally are attracted to implements and their work.

- Never assume children will remain where you last saw them.
- Keep children out of the work area and under the watchful eye of a responsible adult.
- Be alert and shut the implement and tractor down if children enter the work area.
- Never carry children on the tractor or implement. There is not a safe place for them to ride. They may fall off and be run over or interfere with the control of the tow vehicle.
- Never allow children to operate the tow vehicle, even under adult supervision.
- Never allow children to play on the tow vehicle or implement.
- Use extra caution when backing up. Before the tractor starts to move, look down and behind to make sure the area is clear.

SHUTDOWN & STORAGE

- If engaged, disengage power take-off.
- Park on solid, level ground and lower implement to ground or onto support blocks.
- Put tractor in park or set park brake, turn off engine, and remove switch key to prevent unauthorized starting.
- Relieve all hydraulic pressure to auxiliary hydraulic lines.
- Wait for all components to stop before leaving operator's seat.
- Use steps, grab-handles and anti-slip surfaces when stepping on and off the tractor.
- Detach and store implement in an area where children normally do not play. Secure implement using blocks and supports.

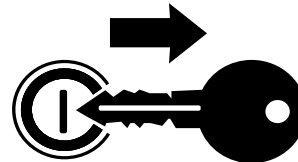

TIRE SAFETY

- Tire changing can be dangerous and must be performed by trained personnel using the correct tools and equipment.
- Always maintain correct tire pressure. Do not inflate tires above recommended pressures shown in the Operator's Manual.
- When inflating tires, use a clip-on chuck and extension hose long enough to allow you to stand to one side and NOT in front of or over the tire assembly. Use a safety cage if available.
- Securely support the implement when changing a wheel.
- When removing and installing wheels, use wheel handling equipment adequate for the weight involved.
- Make sure wheel bolts have been tightened to the specified torque.
- Some attachments may have foam or sealant inside them and must be disposed of properly.

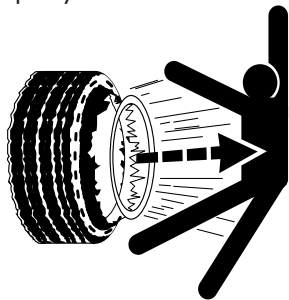

OPERATION SAFETY

- Stay alert for holes, rocks, and roots in the terrain and other hidden hazards. Keep away from drop-offs.
- Stop implement immediately upon striking an obstruction. Turn engine off, remove key, inspect and repair any damage before resuming operation.
- Never operate tractor and implement under trees with low hanging limbs. Operators can be knocked off the tractor and then run over by implement.

TRANSPORT SAFELY

- Comply with federal, state, and local laws.
- Use towing vehicle and trailer of adequate size and capacity. Secure equipment towed on a trailer with tie downs and chains.
- Sudden braking can cause a towed trailer to swerve and upset. Reduce speed if trailer is not equipped with brakes.
- Avoid contact with any overhead utility lines or electrically charged conductors.
- Always drive with load on end of loader arms low to the ground.
- Always drive straight up and down steep inclines with heavy end of a tow vehicle with loader attachment on the "uphill" side.
- Engage park brake when stopped on an incline.
- Maximum transport speed for an attached equipment is 20 mph. DO NOT EXCEED. Never travel at a speed which does not allow adequate control of steering and stopping. Some rough terrains require a slower speed.
- As a guideline, use the following maximum speed weight ratios for attached equipment:
 - 20 mph when weight of attached equipment is less than or equal to the weight of machine towing the equipment.
 - 10 mph when weight of attached equipment exceeds weight of machine towing equipment but not more than double the weight.

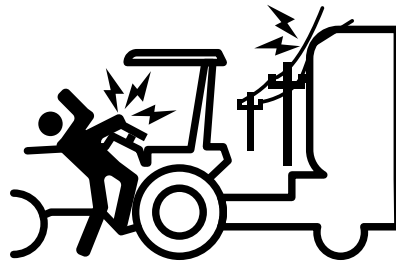

- IMPORTANT: Do not tow a load that is more than double the weight of the vehicle towing the load.

PRACTICE SAFE MAINTENANCE

- Understand procedure before doing work. Refer to the Operator's Manual for additional information.
- Work on a level surface in a clean dry area that is well-lit.
- Lower implement to the ground and follow all shutdown procedures before leaving the operator's seat to perform maintenance.
- Do not work under any hydraulic supported equipment. It can settle, suddenly leak down, or be lowered accidentally. If it is necessary to work under the equipment, securely support it with stands or suitable blocking beforehand.
- Use properly grounded electrical outlets and tools.
- Use correct tools and equipment for the job that are in good condition.
- Allow equipment to cool before working on it.
- Disconnect battery ground cable (-) before servicing or adjusting electrical systems or before welding on implement.
- Inspect all parts. Make certain parts are in good condition & installed properly.
- Replace parts on this implement with genuine ABI Attachments parts only.
- Do not alter this implement in a way which will adversely affect its performance.
- Do not grease or oil implement while it is in operation.
- Remove buildup of grease, oil, or debris.
- Always make sure any material and waste products from the repair and maintenance of the implement are properly collected and disposed.
- Remove all tools and unused parts before operation.



PREPARE FOR EMERGENCIES

- Be prepared if a fire starts.
- Keep a first aid kit and fire extinguisher handy.
- Keep emergency numbers for doctor, ambulance, hospital and fire department near phone.



USE SAFETY LIGHTS AND DEVICES

- Slow moving tractors, skid steers, self-propelled machines, and towed equipment can create a hazard when driven on public roads. They are difficult to see, especially at night. Use the Slow Moving Vehicle sign (SMV) when on public roads.
- Flashing warning lights and turn signals are recommended whenever driving on public roads.



KEEP RIDERS OFF MACHINERY

- Never carry riders on tractor or implement.
- Riders obstruct operator's view and interfere with the control of the tow vehicle.
- Riders can be struck by objects or thrown from the equipment.
- Never use tractor or implement to lift or transport riders.

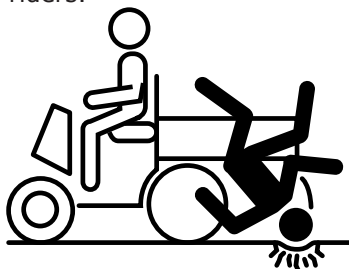

WEAR PERSONAL PROTECTION EQUIPMENT

- Wear protective clothing and equipment appropriate for the job such as safety shoes, safety glasses, hard hat, and ear plugs.
- Clothing should fit snug without fringes and pull strings to avoid entanglement with moving parts.
- Prolonged exposure to loud noise can cause hearing impairment or hearing loss. Wear suitable hearing protection such as earmuffs or earplugs.
- Operating equipment safely requires the operator's full attention. Avoid wearing headphones while operating equipment.

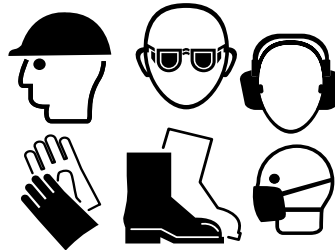

USE SEAT BELT AND ROPS

- ABI Attachments recommends the use of a CAB or roll-over protective structures (ROPS) and seat belt in almost all tow vehicles. Combination of a CAB or ROPS and seat belt will reduce the risk of serious injury or death if the tow vehicle should be upset.
- If ROPS is in the locked-up position, fasten seat belt snugly and securely to help protect against serious injury or death from falling and machine overturn.

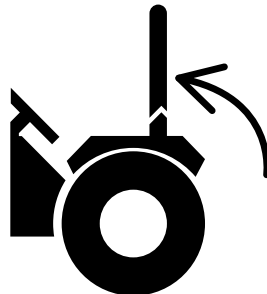

AVOID HIGH PRESSURE FLUIDS HAZARD

- Escaping fluid under pressure can penetrate the skin causing serious injury.
- Before disconnecting hydraulic lines or performing work on the hydraulic system, be sure to release all residual pressure.
- Make sure all hydraulic fluid connections are tight and all hydraulic hoses and lines are in good condition before applying pressure to the system.
- Use a piece of paper or cardboard, NOT BODY PARTS, to check for suspected leaks.
- Wear protective gloves and safety glasses or goggles when working with hydraulic systems.
- DO NOT DELAY. If an accident occurs, see a doctor familiar with this type of injury immediately. Any fluid injected into the skin or eyes must be treated within a few hours or gangrene may result.



AVOID UNDERGROUND UTILITIES

Dig Safe, Call 811 (USA).

- Always contact your local utility companies (electrical, telephone, gas, water, sewer, and others) before digging so that they may mark the location of any underground services in the area.
- Be sure to ask how close you can work to the marks they positioned.



WARNING LABELS:

Labels below are not to scale. Please contact ABI Customer Support at (877)788-7253 if replacements are necessary.



Figure 6.1

COMPLETED ASSEMBLY: 10-90411: REAR HITCH: PIVOTING: Z-23

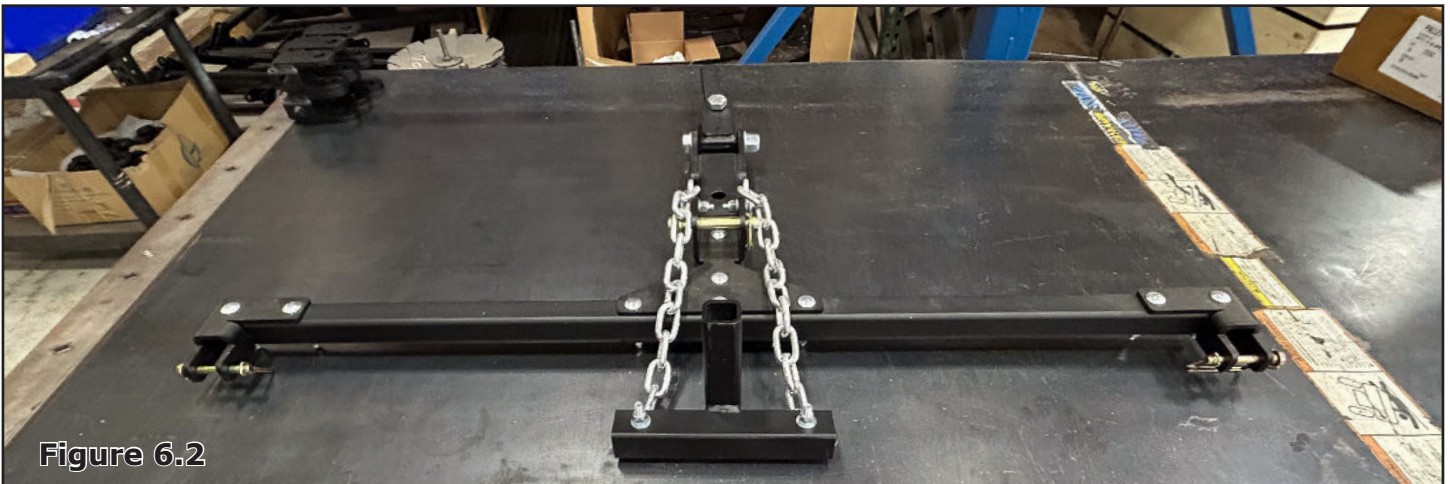

Figure 6.2

REPLACEMENT PARTS:

Some components are considered wear parts and will need to be replaced as they wear out from use. Below are parts descriptions, and photos, to assist you in ordering the correct wear part. To place an order, please contact the ABI Support department at (877)788-7253.

PARTS DESCRIPTION:

10-90411: ASSEMBLY: REAR HITCH: PIVOTING: Z-23

NOTE: THE REAR PIVOTING HITCH IS NOT COMPATIBLE WITH THE ABI FORCE Z-18.

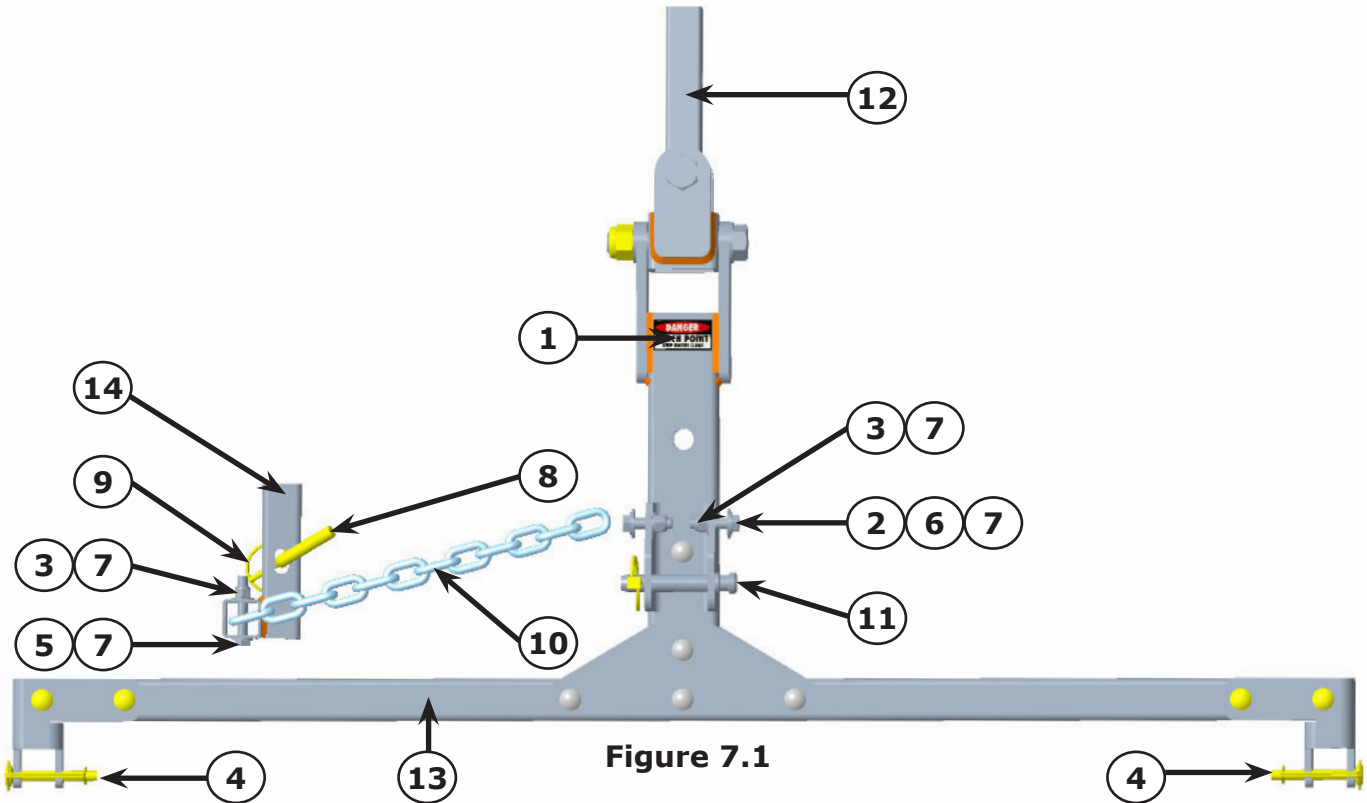

ITEM:	PART #:	DESCRIPTION:	QTY:
1	10-10869	LABEL: PINCH POINT A 1" X 2": FOR TEXTURED TOOLS	1
2	10-20043	BOLT HEX: 3/8x16x1.5: GR5: ZINC	2
3	10-20055	NUT NYLK: 3/8-16: GR5: ZINC	4
4	10-20125	PIN SQ LK: 3/8x2.5	2
5	10-20180	BOLT HEX: 3/8-16x2.5: GR5: ZINC	2
6	10-20194	WSHR SAE: 1/2: ZINC	2
7	10-20195	WSHR SAE: 3/8: ZINC	8
8	10-20221	PIN BENT: 1/2x3.5: ZINC	1
9	10-20232	PIN LYNCH: 1/4x2.125 OALx1.375 UL: ZINC	2
10	10-20302	CHAIN: 5/16	2
11	10-20505	PIN CLEVIS: 5/8x4.438 OALx3 UL: ZINC	1
12	10-40452	PIVOT: MACHINE SIDE (FIGURE 8.1) (PAGE 8)	1
13	10-40453	ASSEMBLY: REAR SECTION: PIVOT HITCH (FIGURE 8.2) (PAGE 8)	1
14	10-40501	WELDMENT: LIFT: Z-23 REAR GROOMING TOOLS	1

PARTS DESCRIPTION:

10-40452: ASSEMBLY: REAR HITCH: MACHINE SIDE

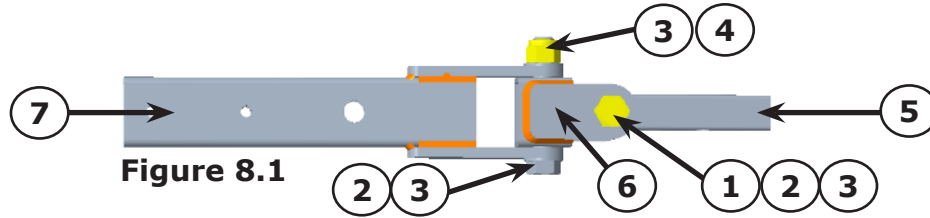

Figure 8.1

ITEM:	PART #:	DESCRIPTION:	QTY:
1	10-20174	BOLT HEX: 3/4-10x3.25: GR5: ZINC	1
2	10-20179	BOLT HEX: 3/4-10x4.5: GR5: ZINC	1
3	10-20197	WSHR SAE: 3/4: GR5: ZINC	3
4	10-20344	NUT NYLK: 3/4-10: GR5: ZINC	2
5	10-31674	BAR: HITCH CONNECT: PIVOT HITCH	1
6	10-40451	WLDMT: MACHINE SIDE PIVOT KNUCKLE: PIVOT HITCH	1
7	10-40461	WLDMT: MAIN TUBE: REAR PIVOT HITCH	1

10-40453: ASSEMBLY: REAR PIVOT WELDMENT

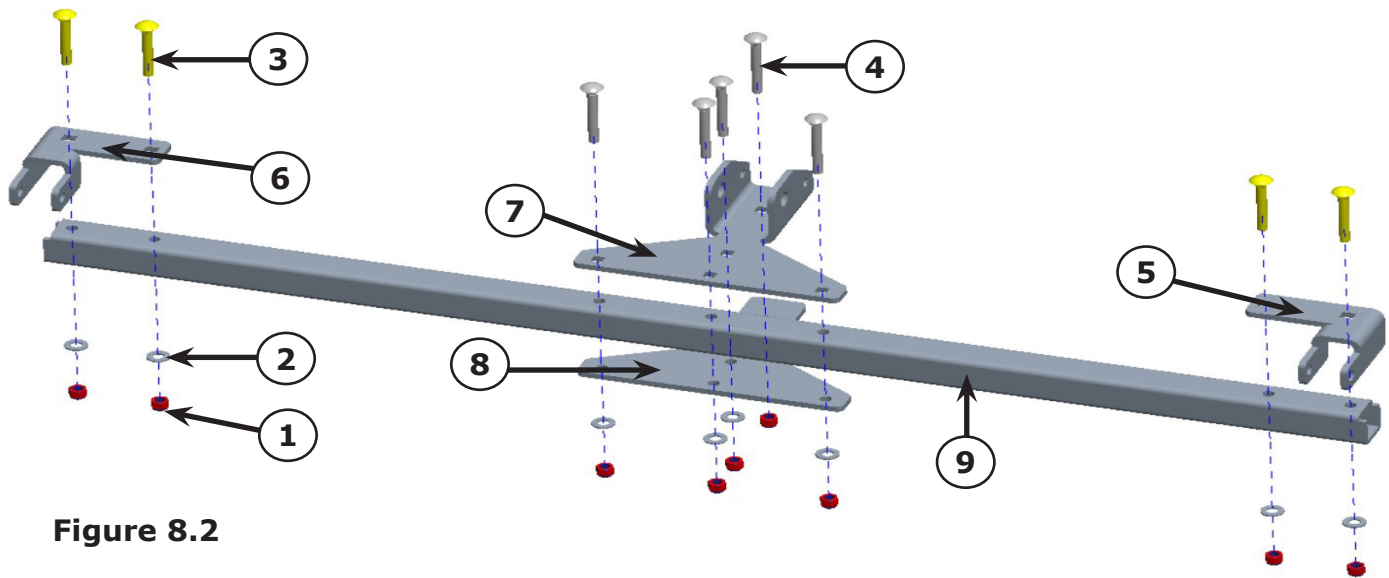
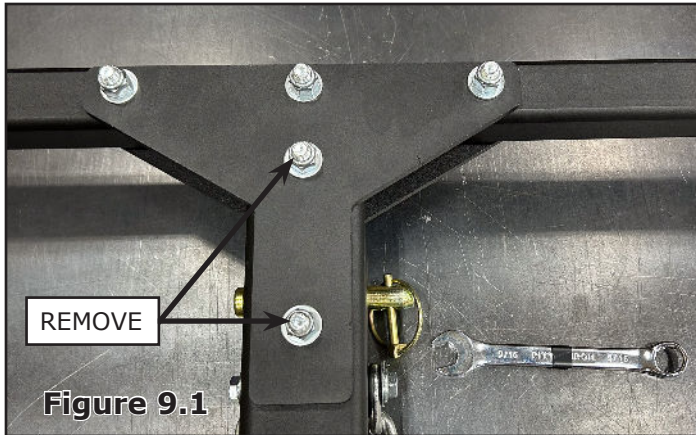

Figure 8.2

ITEM:	PART #:	DESCRIPTION:	QTY:
1	10-20055	NUT NYLK: 3/8-16: GR5: ZINC	9
2	10-20195	WSHR SAE: 3/8: ZINC	9
3	10-20330	BOLT CARR: 3/8-16x2.5: GR5: ZINC	4
4	10-20405	BOLT CARR: 3/8-16x2.75: GR5: ZINC	5
5	10-31665	EAR: TOOL CONNECT RH: PIVOT HITCH	1
6	10-31666	EAR: TOOL CONNECT LH: PIVOT HITCH	1
7	10-31667	BRKT: TOPLINK AND CHAIN MOUNT: PIVOT HITCH	1
8	10-31668	PLATE: BOTTOM WITH GUSSETS: PIVOT HITCH	1
9	10-31671	TUBE: CROSS BAR: PIVOT HITCH	1

ASSEMBLE PIVOT HITCH

Step 1: Remove Two Carriage Bolts



- The Rear Pivoting Hitch is shipped in two pieces (**Figure 9.2**) and needs to be assembled before first time use.
- Locate the five (5) carriage bolts in the center of the Rear Pivot Weldment (**Figure 9.1**).
- With the Nyloc nuts of the Rear Pivot Weldment facing up, remove the nuts, washers, and bolts with a 9/16" wrench.

Step 2: Slide Lift Weldment Into Pivot

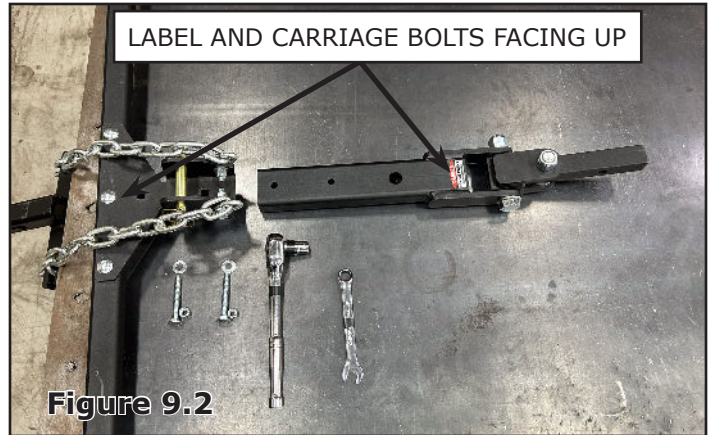

- Flip and move the weldment towards the edge of the table so you can line up the pivot, inside the weldment, easier.
- Slide the hitch inside the weldment, label up, so that both holes for the carriage bolts are lined up correctly (**Figure 9.3**).
- Reinsert both carriage bolts and all washers that you removed in **Step 1** and re-tighten Nyloc nuts by hand.

Step 3: Use Wrench To Tighten All Carriage Bolts

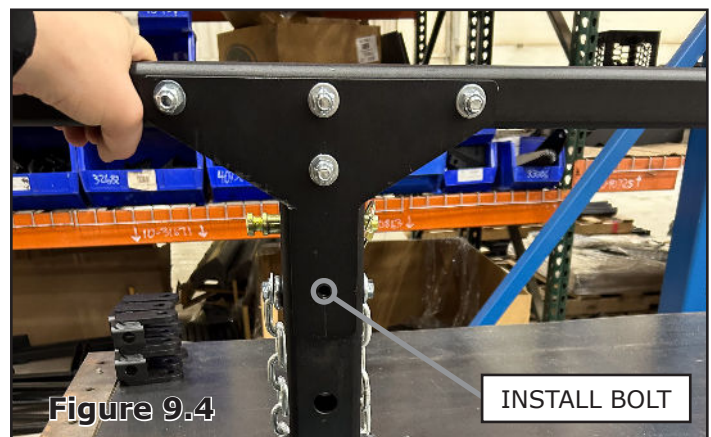
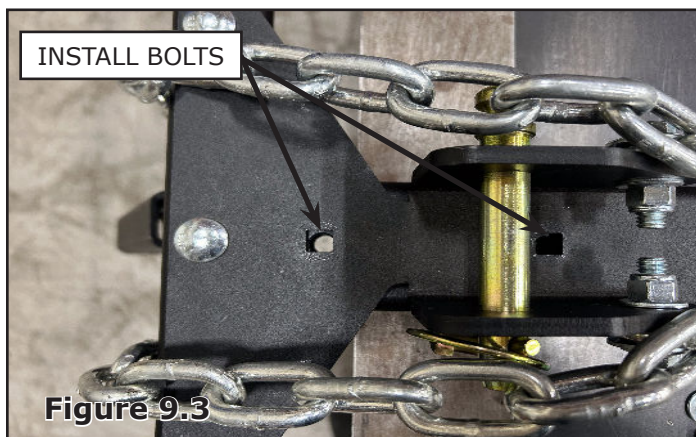

- The five (5) carriage bolts in the center of the Rear Pivot Weldment (**Figure 9.1**) are only hand-tight at initial assembly. This is done so the hitch is easier to install.
- Tilt the Rear Pivot Weldment up using the Pivot Hitch as a base (**Figure 9.4**).
- Use a 9/16" socket & ratchet or a 9/16" wrench to tighten the (5) carriage bolts and Nyloc nuts. It helps to push the carriage bolt in, with your finger, while tightening the Nyloc nut.

NOTE: PLEASE SEE **FIGURE 6.1** ON **PAGE 6** FOR A PHOTO OF A COMPLETED ASSEMBLY.

SETUP FOR FIRST TIME USE:

Step 1: Lower Force Rear Hydraulics

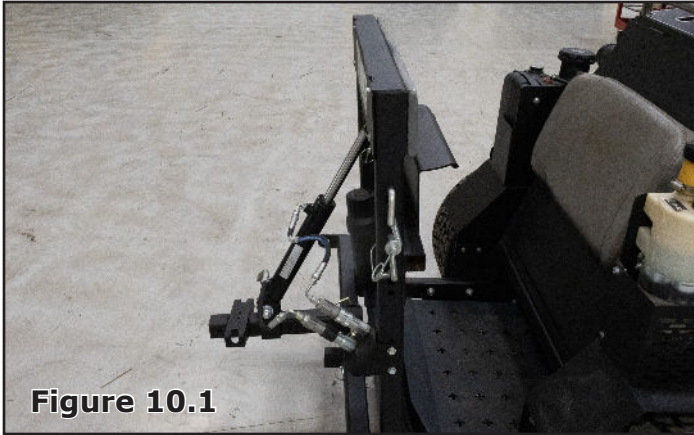

- The Rear Pivoting Hitch is a tool less installation along with all of our ABI Force Rear Attachments.
- Lower the right-most hydraulic lever on your Force to lower the rear hydraulic lift.
- Place the Rear Pivoting Hitch behind the Force, with the carriage bolts facing up.

Step 2: Attach Lift To Hydraulic Hitch

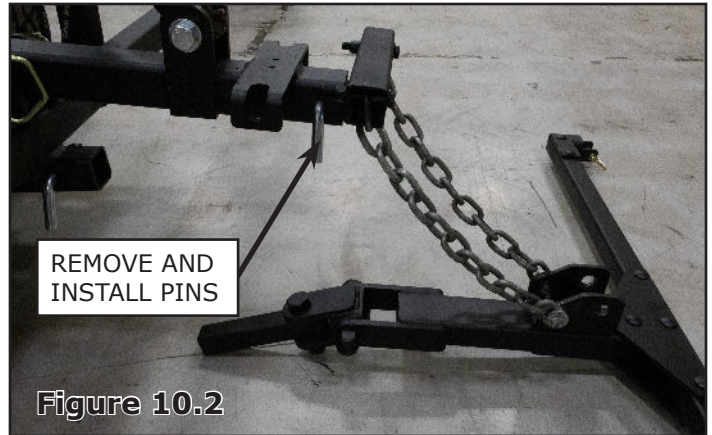

- Remove the bent pin and lynch pin from the lift weldment (attached to chains).
- Slide the lift weldment into the rear hydraulic hitch and reinstall the bent pin and lynch pin (**Figure 10.2**).
- Check to make sure that the chain is free of kinks and has even slack.

Step 3: Attach Pivot To Force Frame

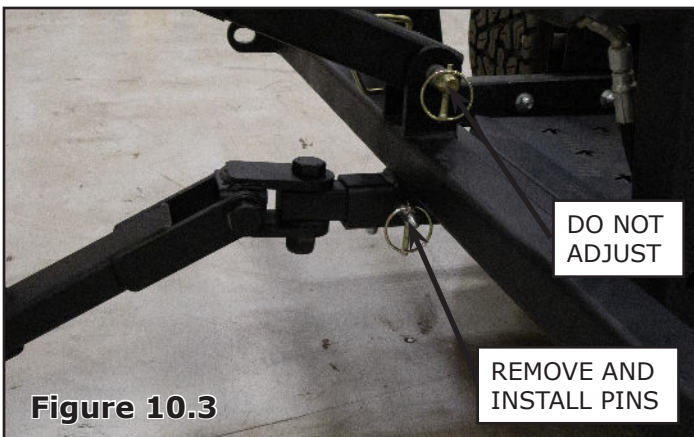

- Raise the Rear Hydraulic Lift up until it stops and the weldment is off the ground.
- Remove the bent pin and lynch pin from the Force Frame Hitch.
- Insert the Frame Pivot into the Force Frame Hitch. Reinstall the bent pin and lynch pin (**Figure 10.3**).

Step 4: Inspect Rear Pivot

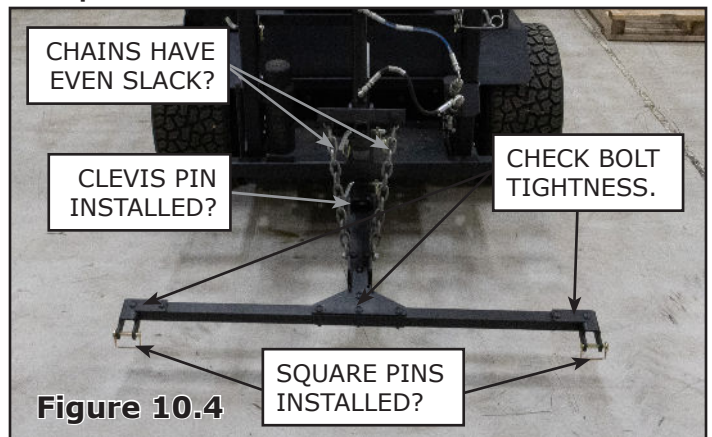

- While the Rear Pivoting Hitch is in the air, Inspect it before first time use.
- Make sure the weldment can swing from right to left freely.
- Make sure all pins are installed and that both chains are free of kinks and have even slack. The installation is now complete.

TOP-LINK ATTACHMENT:

The clevis pin, installed on the Rear Pivoting Hitch (**Figure 11.1**), is used to connect the top-link that comes installed with each rear attachment. The top-link stays with the rear attachment so that the adjustment can be maintained for each use (**Figure 11.2**).

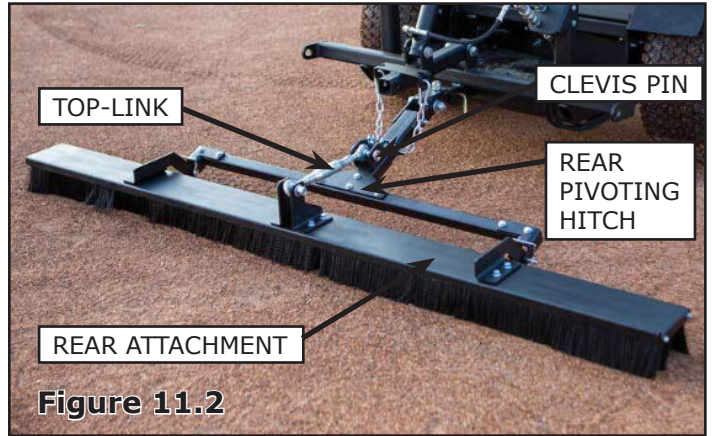
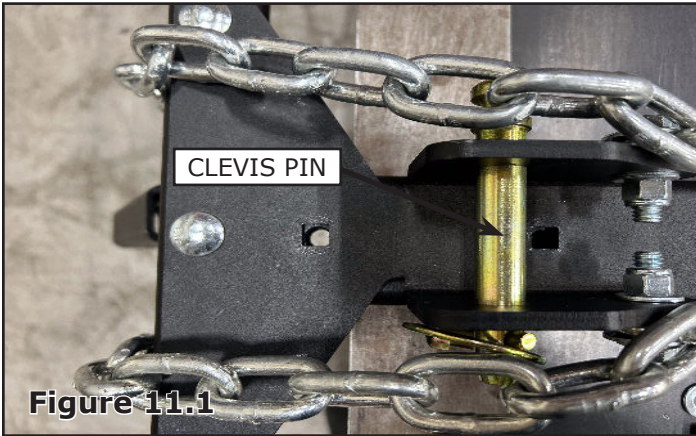

FORCE HYDRAULIC HITCH REVISION:

The Force rear hydraulic hitch was revised, due to design changes in tooling and new tooling available. Please see pictures below. The revision is shown for illustration purposes only and doesn't affect installation of the Rear Pivoting Hitch.

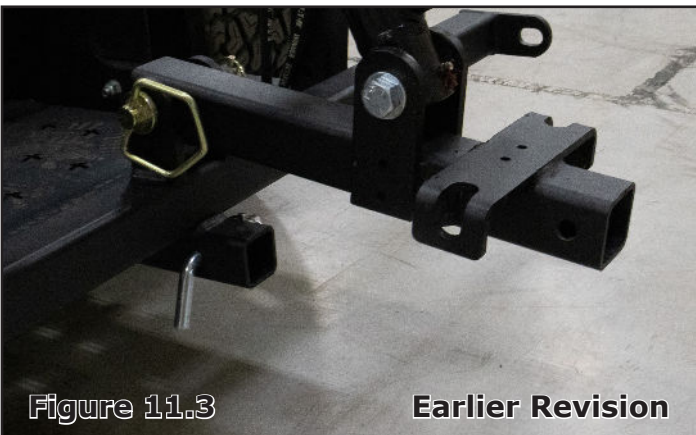

CONTACT INFORMATION

ABI Attachments, Inc
520 S. Byrkit Ave.
Mishawaka, IN 46544

CUSTOMER SUPPORT

Phone: (877)788-7253
Hours: Monday - Friday | 9AM - 5PM EST
Email: support@abiattachments.com
Web: abisupport.com

For additional information on this equipment, or to order replacement parts, please contact our Customer Support Team at (877)788-7253 to speak with one of our representatives.

Warranty and return policy information can also be found on the ABI Support Page under each tool. For additional questions regarding warranty or return policy, please contact our Customer Support Team at (877)788-7253 to speak with one of our representatives.



FORCE